

7M Series

Snap-Acting Pushbutton Switches

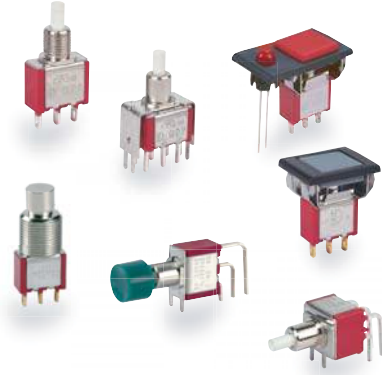

SPECIFICATIONS

CONTACT RATING: Dependent upon contact material
see page 106.

MECHANICAL LIFE: 50,000 make-and-break cycles.

CONTACT RESISTANCE: 20mΩ max. initial @ 2-4VDC
100mA for both silver and gold plated contacts.

INSULATION RESISTANCE: 1,000MΩ min.

DIELECTRIC STRENGTH: 1,000 Vrms min.@sea level.

OPERATING TEMPERATURE: -30°C to 85°C.

MATERIALS

CASE: Diallyl phthalate(DAP) (UL94V-0).

PLUNGER: Glass filled Nylon or Glass filled polyester.(PBT)

BUSHING: Brass,nickel plated.

HOUSING: Stainless Steel.

CONTACT: Brass or Copper alloy, silver or gold plated.

※7MSL/7MDL with gold over silver for plating
(See Page 107)

HOW TO ORDER

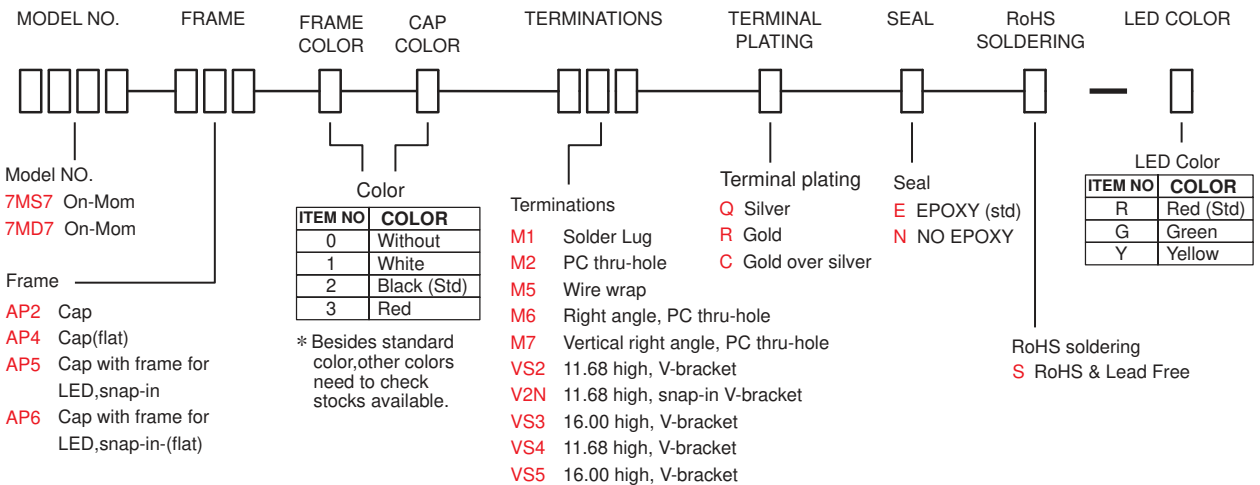
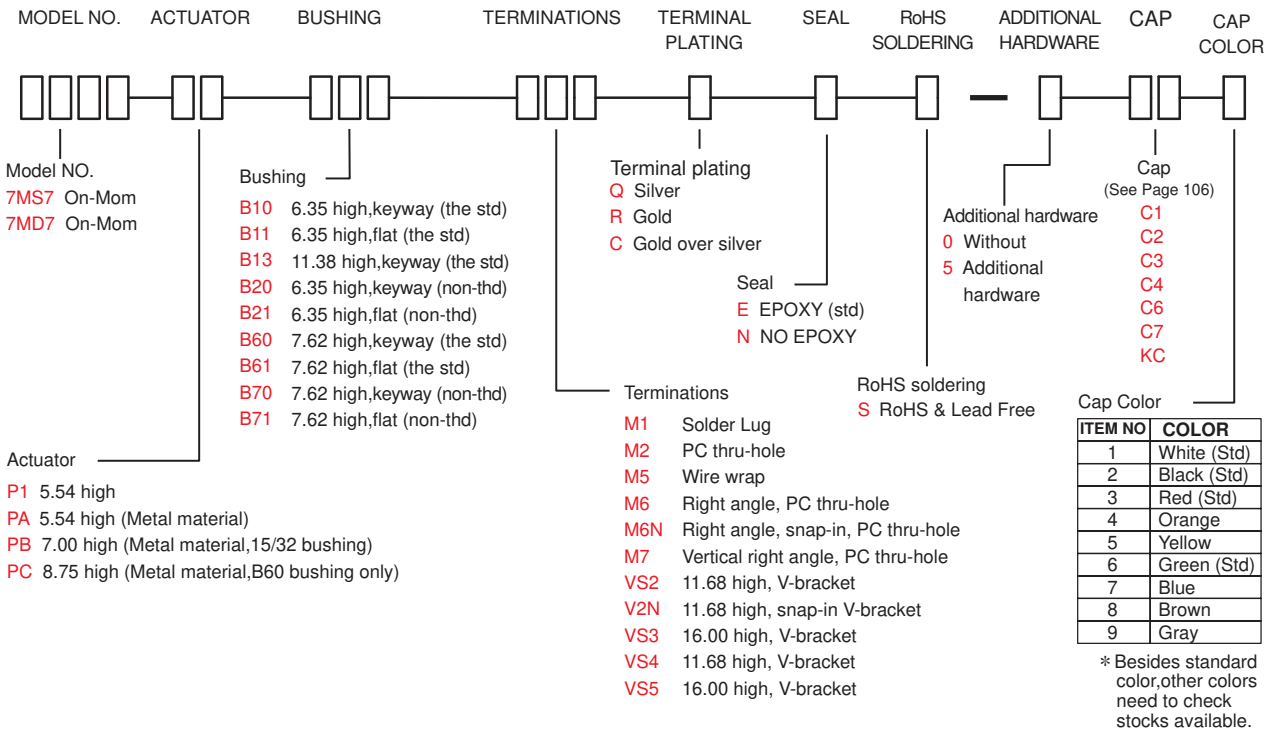

7M Pushbutton Switches

SWITCH FUNCTION

NO. POLES	UL/GSA MODEL NO.	MODEL NO.	SWITCH FUNCTION		CONNECTED TERMINALS / SCHEMATIC	
			POS.1	POS.2	POS.1	POS.2
SP	Q2717	7MS7	ON	MOM	1-3 	1-2
DP	Q2727	7MD7	ON	MOM	1-3,4-6 	1-2,4-5

MOM= MOMENTARY

POLE OPTIONS



7M Pushbutton Switches

M1

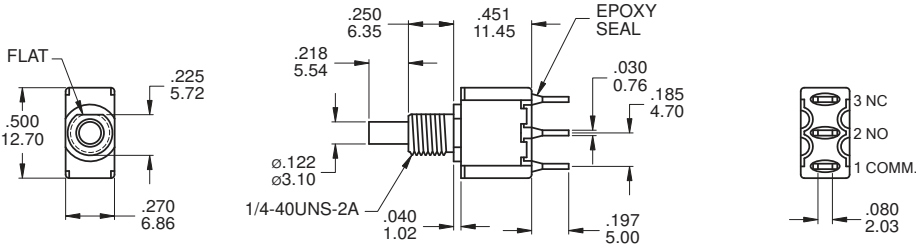

SPDT

Part No. Shown : 7MS7P1B11M1QES

M1

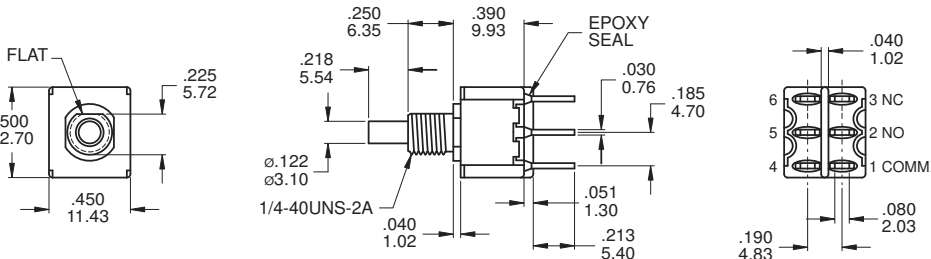

DPDT

Part No. Shown : 7MD7P1B11M1QES

M2

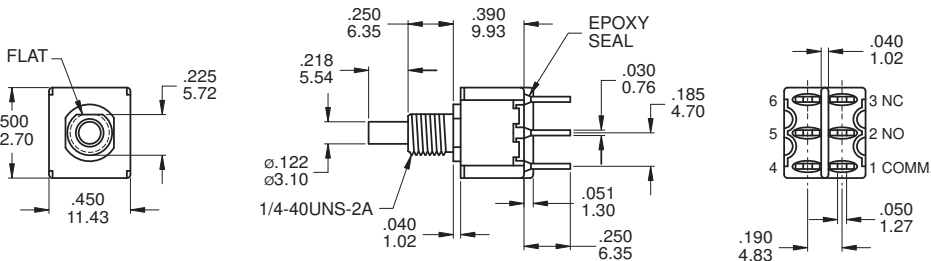

DPDT

Part No. Shown : 7MD7P1B11M2RES

7M Series

Snap-Acting Pushbutton Switches

ACTUATOR OPTIONS

P1

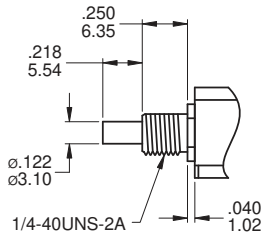

PAB60 handle, metal material

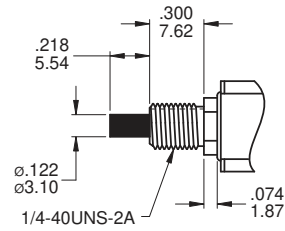

PBB13 handle, metal material

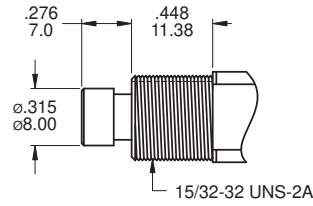

PCB60 handle, metal material

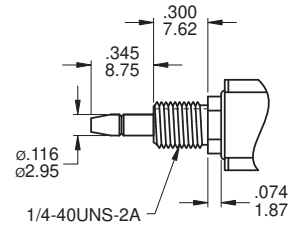

Use with B13 bushing only

Use with B60 bushing std
* PC Actuator only for KC Cap

BUSHING OPTIONS

B10 THD STD
B20 NON-THD

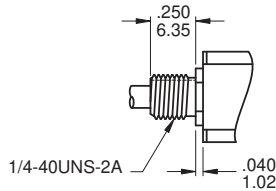
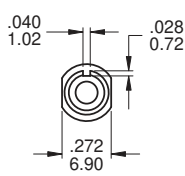

B11 THD STD
B21 NON-THD

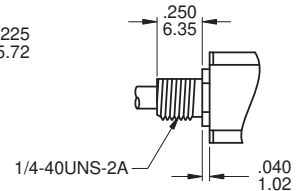
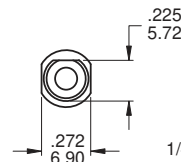

B60 THD STD
B70 NON-THD

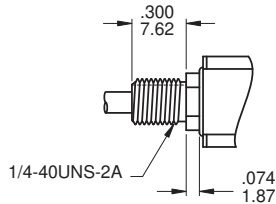
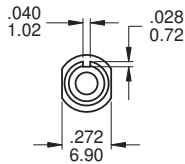

B61 THD STD
B71 NON-THD

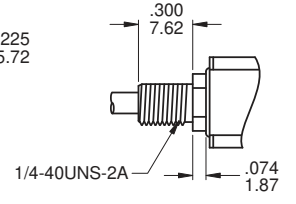
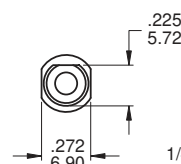

TERMINATION OPTIONS

M1 Solder lug

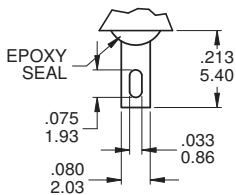

.030(0.76) THK.

M2 PC Thru-hole

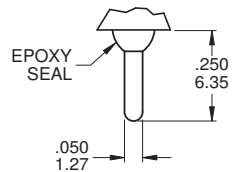

.030(0.76) THK.

M3 Quick connect

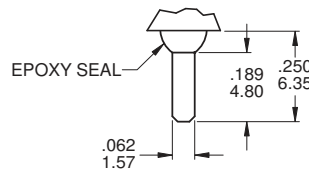

.030(0.76) THK.

M5 Wire Wrap

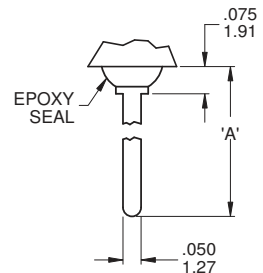

.030(0.76) THK.

OTHER TERMINATION OPTIONS

- M6** Right angle P.C. Mount
- M7** Right angle P.C. Mount
- VS2** Vertical bracket P.C. Mount
- VS3** Vertical bracket P.C. Mount
- VS4** Vertical bracket P.C. Mount
- VS5** Vertical bracket P.C. Mount

- M6N** Right angle P.C. Mount Snap-in bracket
- V2N** Vertical bracket P.C. Mount Snap-in bracket

OPTION CODE	DIM. 'A'
M51	.750 (19.50)
M52	.964 (24.48)
M53	.426 (10.80)
M54	.650 (16.50)

7M Pushbutton Switches



M6

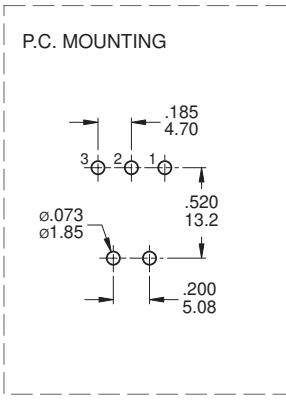
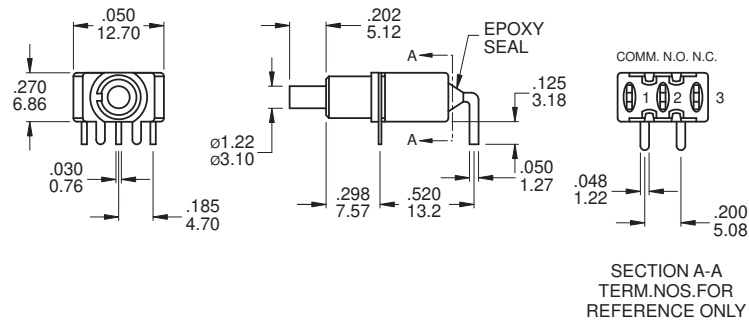

SPDT

Part No. Shown : 7MS7P1B20M6QES

M6

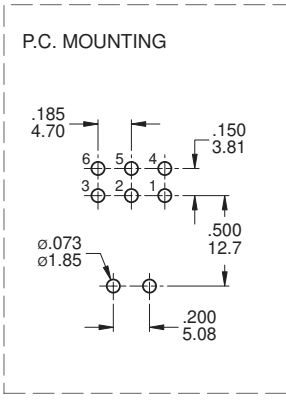
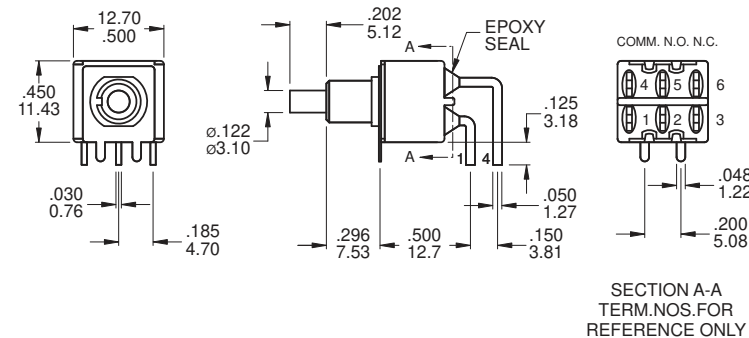

DPDT

Part No. Shown : 7MD7P1B20M6QES

M7

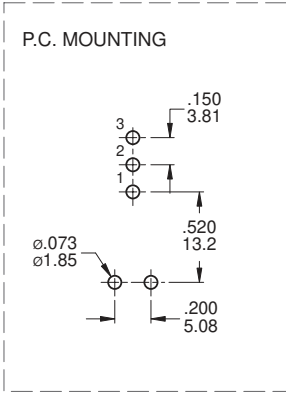
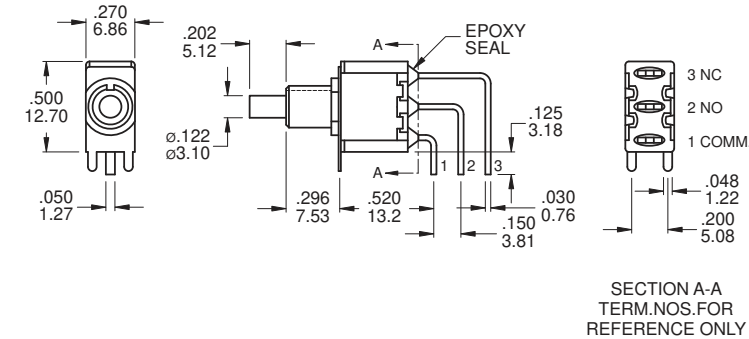

SPDT

Part No. Shown : 7MS7P1B20M7QES

M7

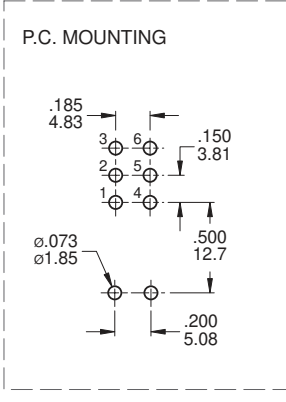
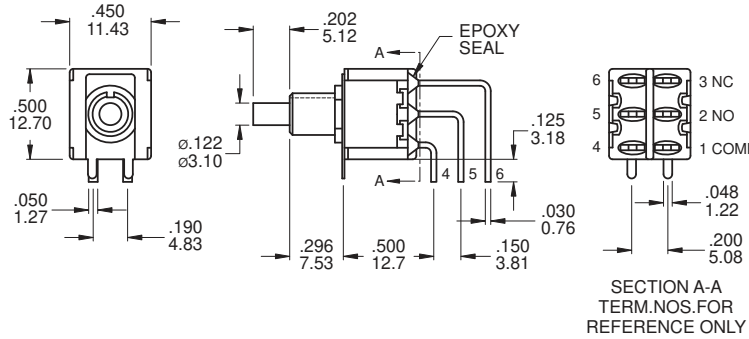

DPDT

Part No. Shown : 7MD7P1B20M7RES

7M Series

Snap-Acting Pushbutton Switches

VS2 - VS3

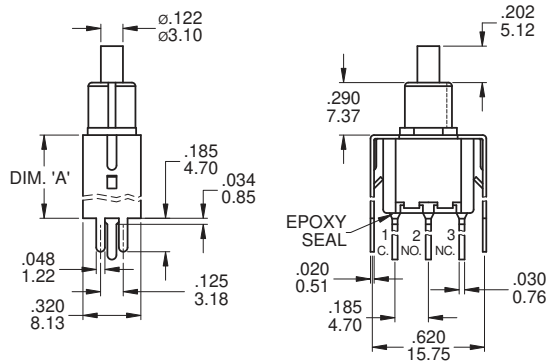

OPTION CODE	DIM. 'A'
VS2	.460 11.68
VS3	.630 16.00

P.C. MOUNTING

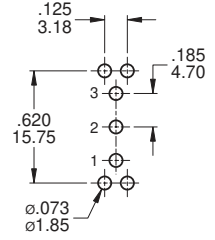

SPDT

Part No. Shown : 7MS7P1B20VS2RES

VS2 - VS3

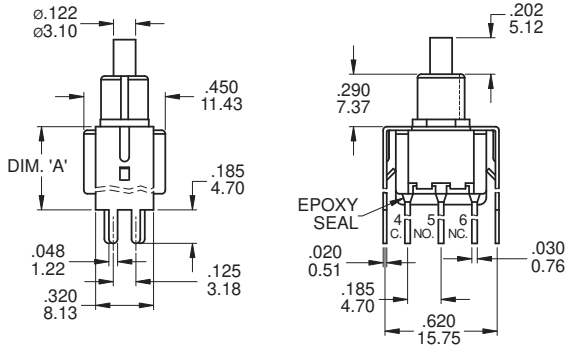

OPTION CODE	DIM. 'A'
VS2	.460 11.68
VS3	.630 16.00

P.C. MOUNTING

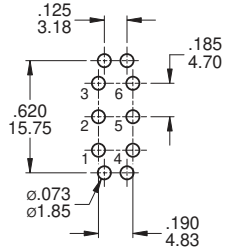

DPDT

Part No. Shown : 7MD7P1B20VS2QES

VS4 - VS5

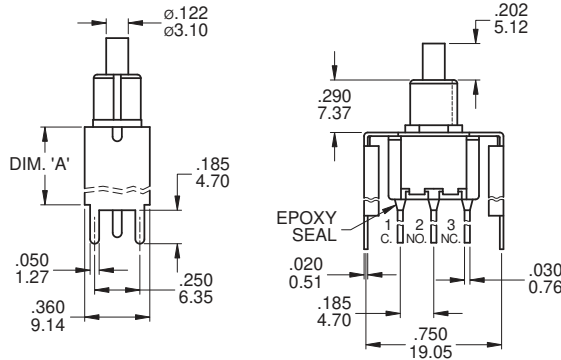

OPTION CODE	DIM. 'A'
VS4	.460 11.68
VS5	.630 16.00

P.C. MOUNTING

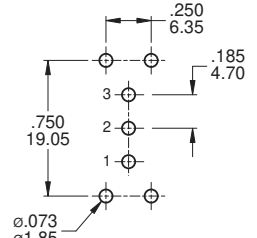

SPDT

Part No. Shown : 7MS7P1B20VS4QES

VS4 - VS5

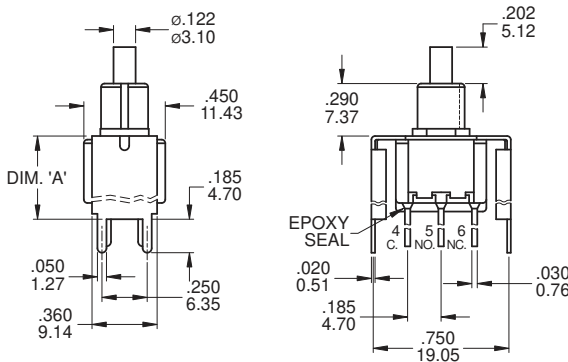

OPTION CODE	DIM. 'A'
VS4	.460 11.68
VS5	.630 16.00

P.C. MOUNTING

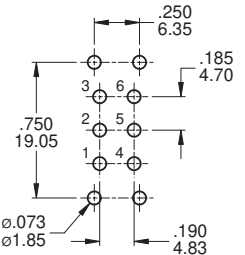

DPDT

Part No. Shown : 7MD7P1B20VS4QES

SNAP-IN TERMINATION OPTIONS

M6N

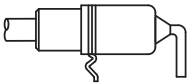

V2N

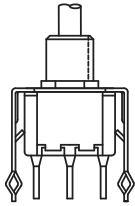
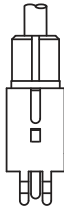

PANEL MOUNTING



7M
Pushbutton Switches

AP2 CAP & FRAME

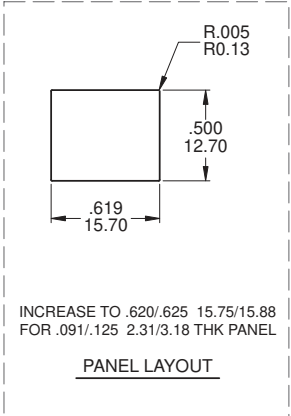
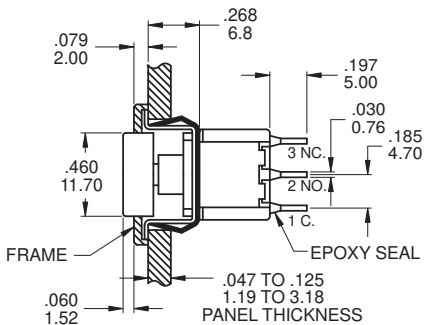
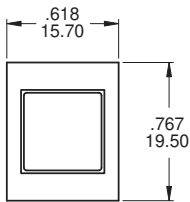

SPDT

Part No. Shown : 7MS7AP223M1QES

AP2 CAP & FRAME

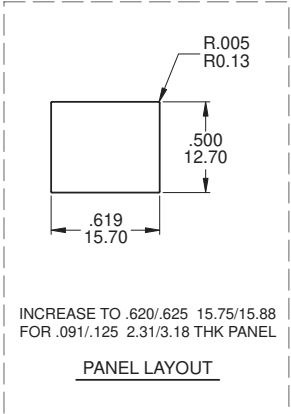
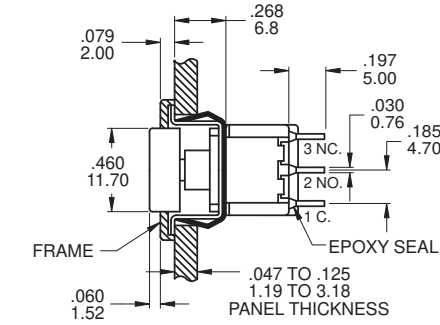
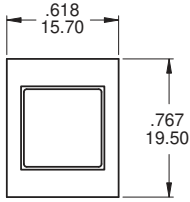

DPDT

Part No. Shown : 7MD7AP223M1QES

AP4 CAP & FRAME

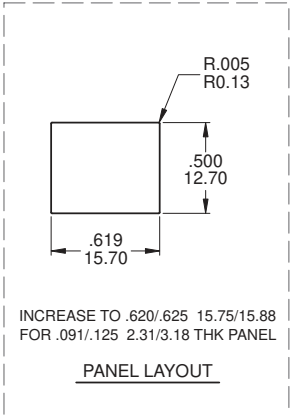
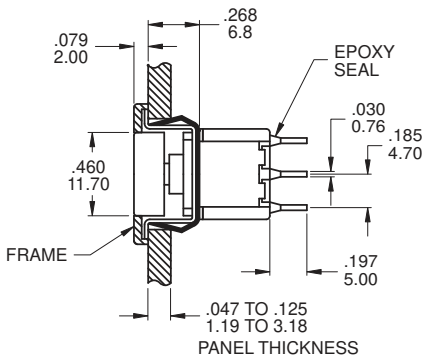
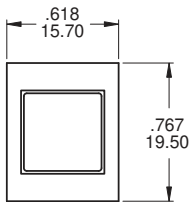

SPDT

Part No. Shown : 7MS7AP429M1RES

7M Series

Snap-Acting Pushbutton Switches

PANEL MOUNTING

AP4 CAP & FRAME

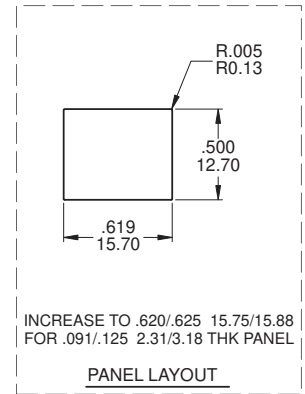
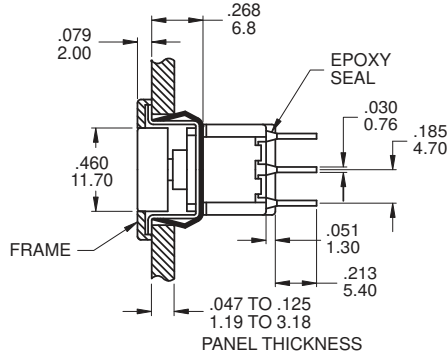
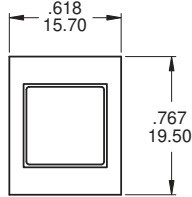

DPDT

Part No. Shown : 7MD7AP423M1RES

AP5 CAP & FRAME

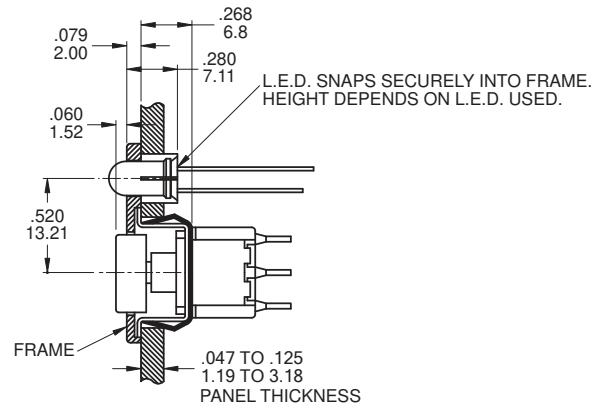
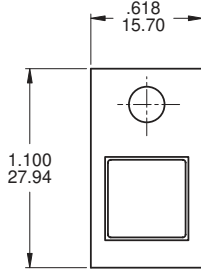

SPDT

Part No. Shown : 7MS7AP523M1QES

AP6 CAP & FRAME

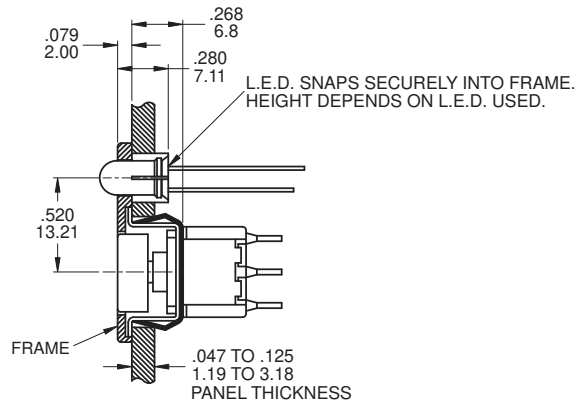
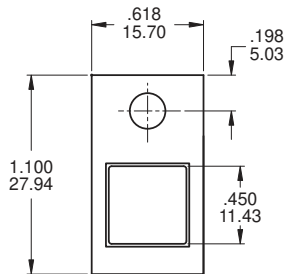

SPDT

Part No. Shown : 7MS7AP629M1RES

FOR AP5/AP6

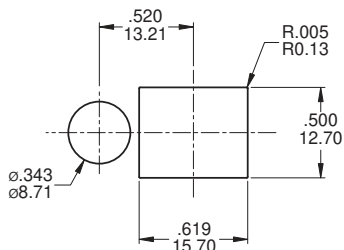

PANEL LAYOUT

CAP AND FRAME COLORS

OPTION CODE	COLOR
1	WHITE
2	BLACK(std)
3	RED

LED COLORS

OPTION CODE	COLOR
R	RED(std)
G	GREEN
Y	YELLOW

* Besides standard color, other colors need to check stocks available.